

Other Protistor® Fuses Ferrule Fuses 10x38 gRB - 690VAC

690V AC
gRB - from 1 up to 30 A
Size: 10x38



The fuse preselection table below indicates: 

- rated current (or rating) I_N
- pre-arcing I^2t (I^2t_D) at 1 ms
- total operating I^2t (I^2t_{tt}) at 690V, $\cos \varphi=0.15$, and for a total operating time from 8 to 10 ms
- dissipated power P_N at the rated current I_N , and at 0.8 I_N , in steady state
- Nominal breaking capacity, checked by tests made in accordance with IEC standard.

Voltage Rating (VAC)	Rated current I_N (A)	Pre-arcing I^2t I^2t_p (A ² s)	Total I^2t at 660VAC I^2t_{tt} (A ² s)	Dissipated power		Peak arc voltage (V)	Breaking capacity I (kA)
				at I_N (W)	at 0.8 I_N (W)		
690	1	0,075	0,28	0,9	0,52	2500	160 kA 690 V (IEC)
	1,25	0,115	0,36	1,25	0,7		
	1,5	0,185	0,57	1,5	0,81		
	2	0,42	1,3	2	1,1		
	2,5	0,88	2,7	2,1	1,15		
	3	1,55	4,6	2,3	1,25		
	4	4	12	2,6	1,35		
	5	8,6	25	2,7	1,4		
	6	15	44	2,9	1,5		
	8	3,3	33	2,4	1,35	1450	
	10	5,4	55	3,4	1,85		
	12,5	8,5	82	3,4	1,9		
	16	16	145	4,1	2,3		
	20	230	250	4,3	2,4		
	25	58	470	4,7	2,7		
30 (32*)	96	740	5	2,9			

* Non approval rating

Semiconductor (AC) fuses



Other Protistor® Fuses French Ferrule 10x38 gRB - 690VAC

Maximum values of total operating I^2t and total operating times

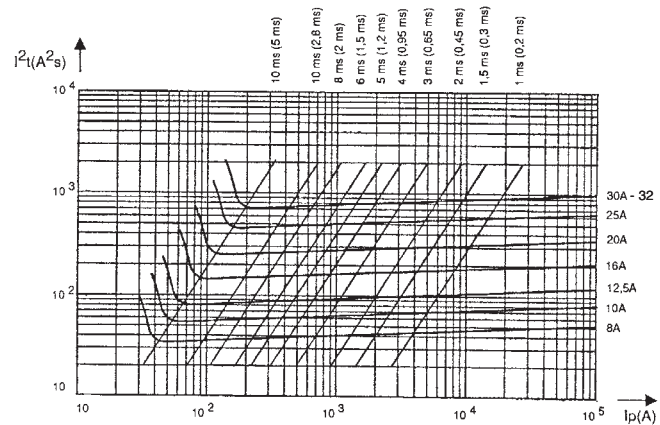
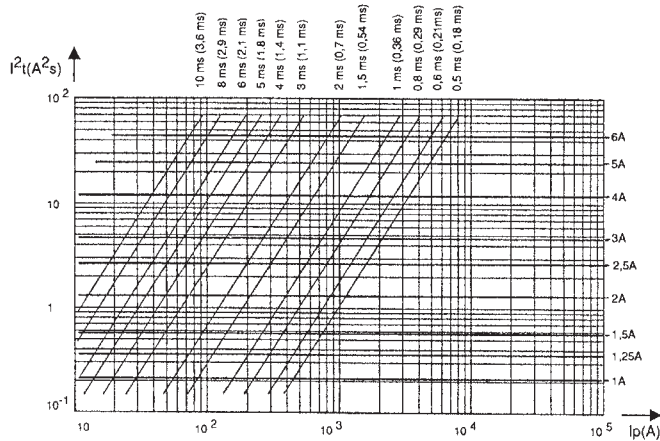

Arc voltage

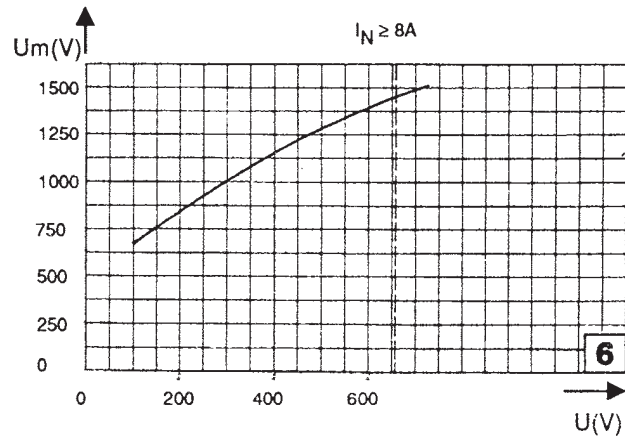
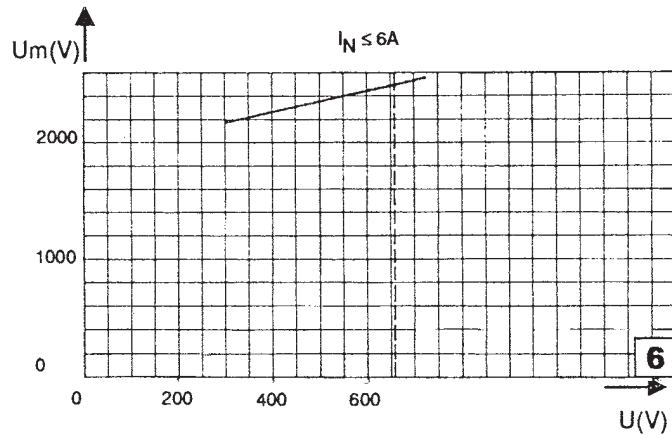

Multiplier coefficient

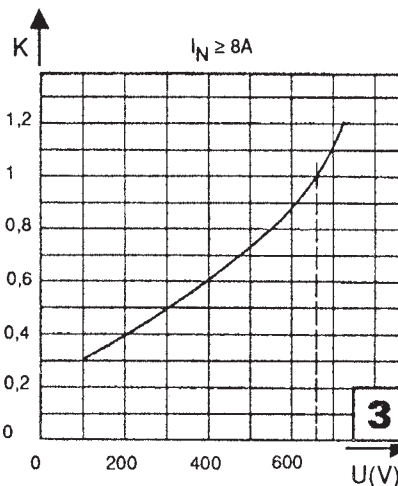
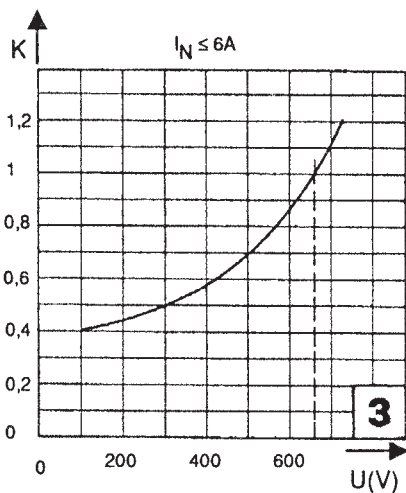

Other Protistor® Fuses Ferrule Fuses 10x38 gRB - 690VAC

Time-current characteristics (1 to 6 A)

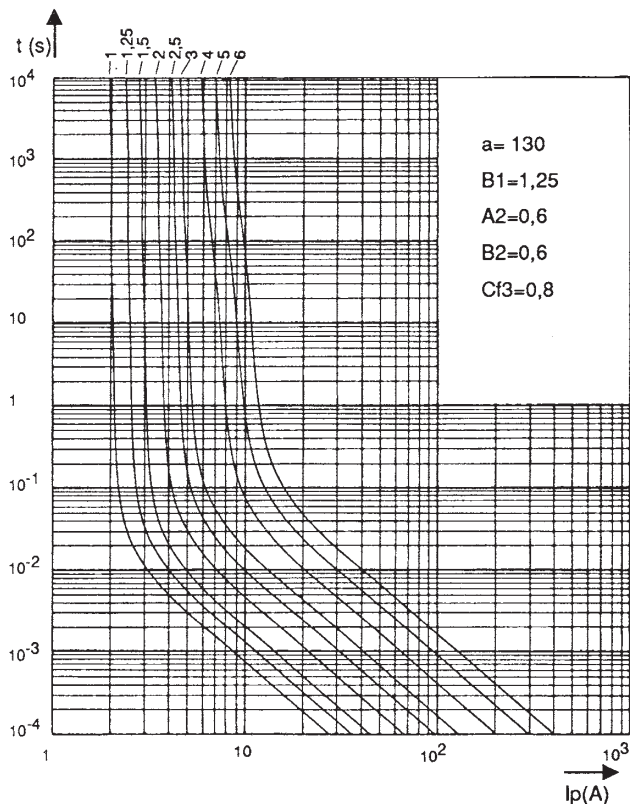

Cut-off characteristics

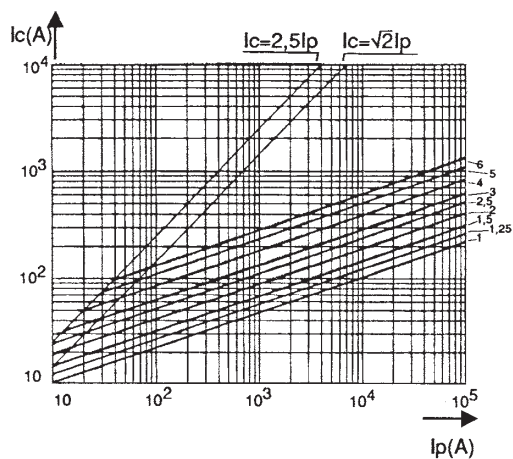

Time-current characteristics (8 to 30 A)

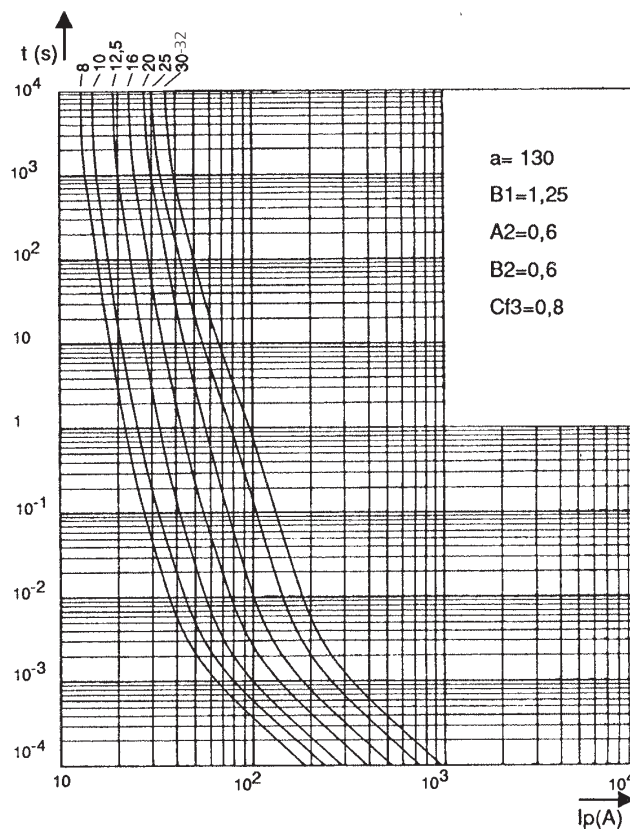

Cut-off characteristics

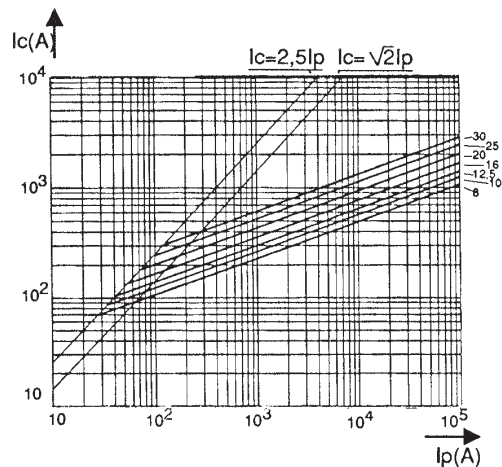

Other Protistor® Fuses Ferrule Fuses 10x38 gRB - 690VAC

Dimensions / Reference / Ref. No. 

Rating (A)	Designation	Ref. Number	Catalog Number
1	6,9 gRC 10-01 - A070 gRC 01 T13	Z330279	FR10GB69V1
1,25	6,9 gRB 10-1,25 - A070 gRB 1.25 T13	X330001	FR10GB69V1.25
1,5	6,9 gRB 10-1,5 - A070 gRB 1.5 T13	Y330002	FR10GB69V1.5
2	6,9 gRB 10-02 - A070 gRB 02 T13	Z330003	FR10GB69V2
2,5	6,9 gRB 10-2,5 - A070 gRB 2.5 T13	A330004	FR10GB69V2.5
3	6,9 gRB 10-03 - A070 gRB 03 T13	B330005	FR10GB69V3
4	6,9 gRB 10-04 - A070 gRB 04 T13	C330006	FR10GB69V4
5	6,9 gRB 10-05 - A070 gRB 05 T13	D330007	FR10GB69V5
6	6,9 gRB 10-06 - A070 gRB 06 T13	E330008	FR10GB69V6
8	6,9 gRB 10-08 - A070 gRB 08 T13	F330009	FR10GB69V8
10	6,9 gRB 10-10 - A070 gRB 10 T13	G330010	FR10GB69V10
12,5	6,9 gRB 10-12,5 - A070 gRB 12.5 T13	H330011	FR10GB69V12.5
16	6,9 gRB 10-16 - A070 gRB 16 T13	J330012	FR10GB69V16
20	6,9 gRB 10-20 - A070 gRB 20 T13	K330013	FR10GB69V20
25	6,9 gRB 10-25 - A070 gRB 25 T13	L330014	FR10GB69V25
30	6,9 gRB 10-30 - A070 gRB 30T13	M330015	FR10GB69V30
32*	6,9 gRB 10-32 - A070 gRB 32T13	Y330278	FR10GB69V32

* Non approval rating

DC working voltage possibilities

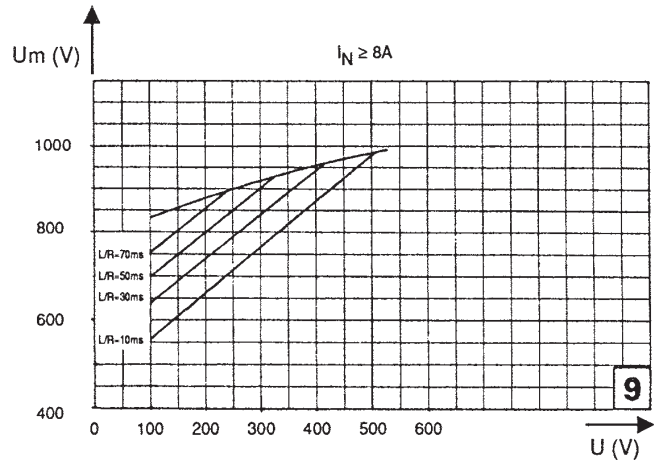
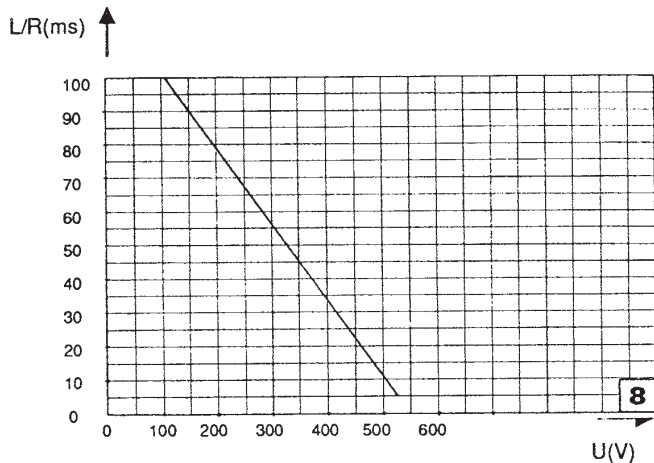

↑ Above: Curve indicating the maximum time constant L/R of the fault path as a function of the DC voltage U , for the rated currents from 1 to 30 A of this range.

Time-current characteristics: Curves indicate, for each rated current, pre-arcing time as a function of RMS value of pre-arcing current I .

Tolerances on this current:
 $\pm 10\%$ = ratings from 1 to 6 A
 $\pm 9\%$ = ratings from 8 to 30 A

Fuses with "gR" characteristics can eliminate all overloads.

They do not show any minimum breaking capacity but limit currents of non-operation or operation in compliance with standard VDE 636/23.

Cut off characteristics: Curves indicate, for each rated current, the peak value I_c that the current may reach as a function of prospective fault current I_p .

Without trip-indicator
 Max. weight 10g
 Packaging: per 10 pieces

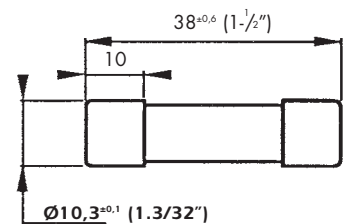

Other Protistor® Fuses

Ferrule Fuses

10x38 URB/URD/URL - 500 to 600 VAC



Extremely high breaking capacity fuses:
Protection of power semiconductors complying with IEC standard 60269.1 and 4.

500 - 600 VAC voltage rating

aR-CLASS according to VDE 636-23 IEC 60269-4

Without blown fuse indication 0.10 up to 0.80 A**

With trip-indicator (1 to 30 A), a Ferraz Shawmut speciality*

Main Characteristics

Voltage rating U_N (VAC)	Class	Current rating I_N (A)	Pre-arcing $I^2t @ 1 \text{ ms}$ I^2tp (A ² s)	Total clearing $I^2t @ U_N$ I^2tt (A ² s)	Watts loss		Tested breaking capacity
					0.8 I_N	I_N	
600 V without blown fuse indicator	URD **	100 mA	/	1.2 10 ⁻³	0.23	0.4	200 kA @ 600 V
		125 mA		2.3 10 ⁻³	0.25	0.44	
		160 mA		5.2 10 ⁻³	0.28	0.48	
		200 mA		8 10 ⁻³	0.34	0.58	
		250 mA		18 10 ⁻³	0.35	0.60	
		315 mA		33 10 ⁻³	0.42	0.73	
		400 mA		56 10 ⁻³	0.46	0.80	
		500 mA		0.100	0.46	0.80	
		630 mA		0.18	0.52	0.90	
		800 mA		0.44	0.58	1	
500 V with trip-indicator	URD	1 A	0.40	3.6	2.8	0.5	50 kA @ 500 V
		1.25 A	0.13	1.7	0.52	0.91	
		1.6 A	0.31	2.2	0.58	1	
		2 A	0.65	3.1	0.63	1.1	
		2.5 A	1.65	5.9	0.63	1.1	
		3.15 A	2.80	9	0.86	1.5	
	4 A	5.30	16	1.1	1.8		
	5 A	12.7	36	1.1	1.8		
	URD	6 A	1.3	47	0.73	1.35	50 kA @ 500 V
		8 A	2.3	80	0.83	1.55	
		10 A	3.6	110	1	1.9	
		12 A	5.25	150	1.3	2.3	
		16 A	9.30	200	1.7	3.1	
		20 A	16	290	1.7	3.2	
	URL	25 A	37	580	2.9	4.25	50 kA @ 500 V
		30 A	58	900	3.5	5.1	

* minimum operating voltage for trip-indicator: 20 V

** higher ratings without blown fuse indicator see 10x38gRB - 690 VAC



Other Protistor® Fuses

Ferrule Fuses

10x38 URB/URD - 500 to 600 VAC

10.3x38 - Without blown fuse indicator

Current Rating	Designation	Ref. Number	Catalog Number
100 mA	A 060 URD 0.100T13	H077632	A060UD0.100T13
125 mA	A 060 URD 0.125T13	J077633	A060UD0.125T13
160 mA	A 060 URD 0.160T13	K077634	A060UD0.160T13
200 mA	A 060 URD 0.200T13	L077635	A060UD0.200T13
250 mA	A 060 URD 0.250T13	M077636	A060UD0.250T13
315 mA	A 060 URD 0.315T13	N077637	A060UD0.315T13
400 mA	A 060 URD 0.400T13	P077638	A060UD0.400T13
500 mA	A 060 URD 0.500T13*	Q077639	A060UD0.500T13
630 mA	A 060 URD 0.630T13*	R077640	A060UD0.630T13
800 mA	A 060 URD 0.800T13*	S077641	A060UD0.800T13

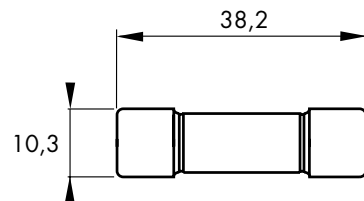

* UL Recognized 

Fuses mounted in clips or fuse disconnectors

10.3x38 - With trip-indicator

Current Rating	Designation	Ref. Number	Catalog Number
1 A	A 050 URD 001 T13 I	P076925	A050URD1T13I
1.25 A	A 050 URD 001.2 T13 I	H076597	A050URD1.2T13I
1.6 A	A 050 URD 001.6 T13 I	G076596	A050URD1.6T13I
2 A	A 050 URD 002 T13 I	Q076926	A050URD2T13I
2.5 A	A 050 URD 002.5 T13 I	F076595	A050URD2.5T13I
3.15 A	A 050 URD 003 T13 I	R076927	A050URD3T13I
4 A	A 050 URD 004 T13 I	S076928	A050URD4T13I
5 A	A 050 URD 005 T13 I	T076929	A050URD5T13I
6 A	A 050 URB 006 T13 I	V076930	A050URB6T13I
8 A	A 050 URB 008 T13 I	W076931	A050URB8T13I
10 A	A 050 URB 010 T13 I	X076932	A050URB10T13I
12 A	A 050 URB 012 T13 I	Y076933	A050URB12T13I
16 A	A 050 URB 016 T13 I	Z076934	A050URB16T13I
20 A	A 050 URB 020 T13 I	A076935	A050URB20T13I
25 A	A 050 URL 025 T13 I	B076936	A050URL25T13I
30 A	A 050 URL 030 T13 I	C076937	A050URL30T13I

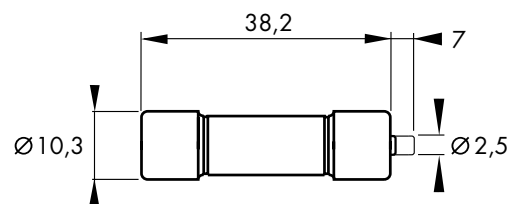

Fuses with trip indicator mounted in clips

Other Protistor® Fuses Ferrule Fuses

10x38 URB/URD - 500 to 600 VAC

Electrical characteristics

Time vs current characteristics

WITHOUT BLOWN FUSE INDICATOR

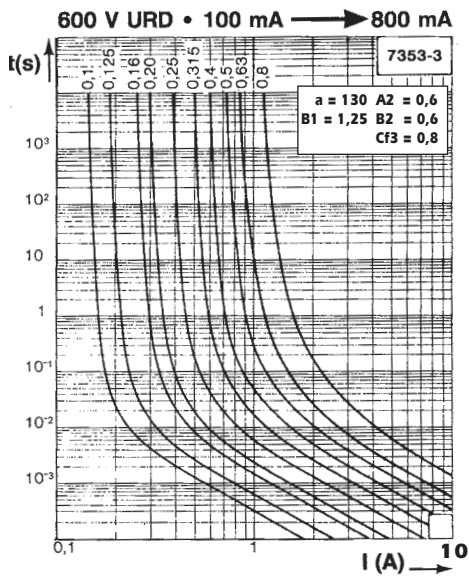

WITH TRIP INDICATOR

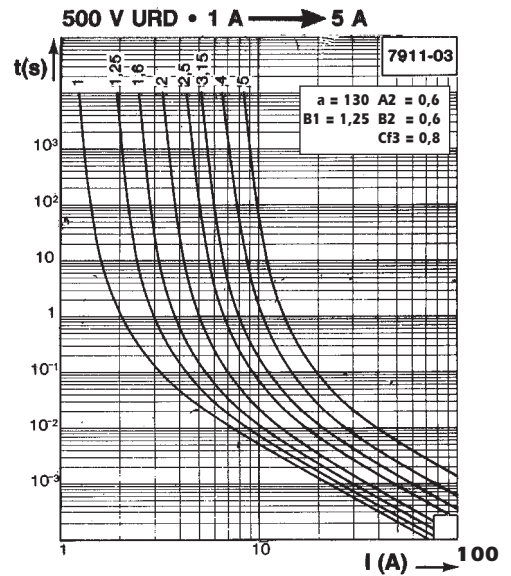

These curves indicate, for each rated current, pre-arcing time vs. R.M.S. pre-arcing current.
Tolerance for mean pre-arcing current $\pm 10\%$

WITH TRIP INDICATOR

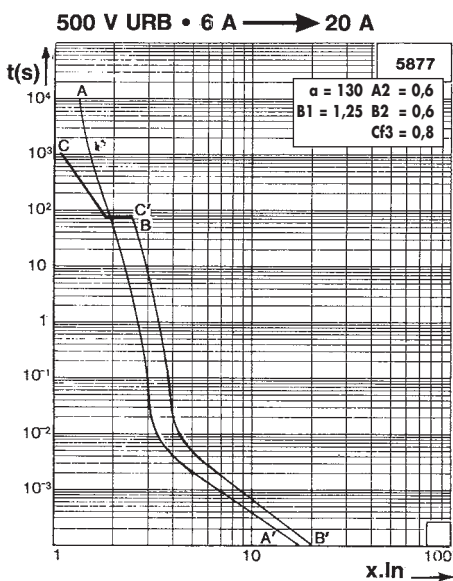

WITH TRIP INDICATOR

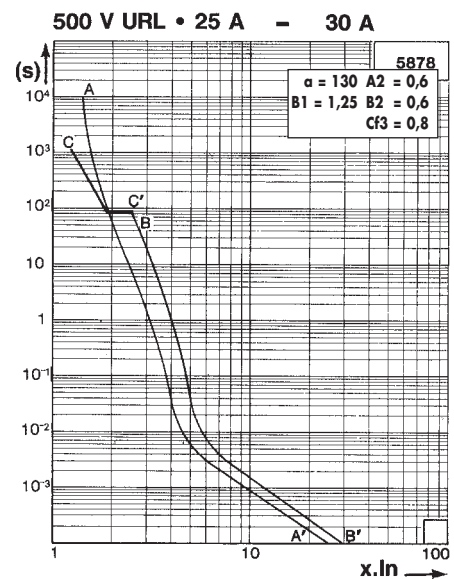

These curves indicate, for each rated current, pre-arcing time vs. R.M.S. pre-arcing current.
as a multiple of current rating.



Other Protistor® Fuses

Ferrule Fuses

10x38 URB/URD - 500 to 600 VAC

Corrective factor - Peak arc voltage

Corrective factor

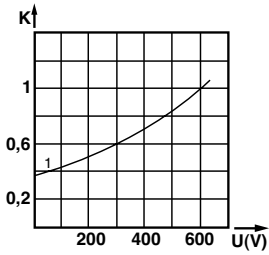

600 V UR
1 : 0.1 up to 0.8 A

These mean curves show the variation of the total clearing time (I^2t_t) and the total clearing duration t_t as a function of operating voltage U.

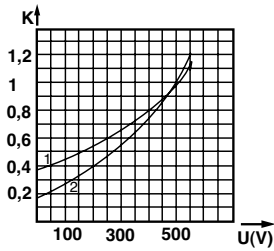

500 V UR
1 : 1 up to 5 A
2 : 6 up to 30 A

Peak arc voltage

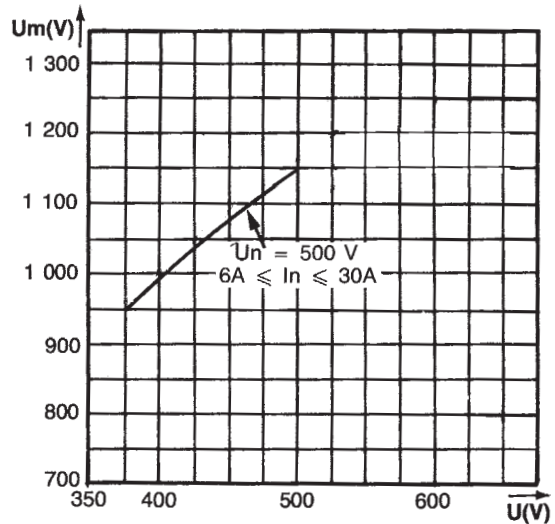

This curve shows the peak value U_m of the arc voltage which appears across the fuse link as a function of the operating voltage U @ $\cos \varphi = 0.15$.

D.C. Application data for fuses with trip indicator

500 V URD $I_N \geq 6A$

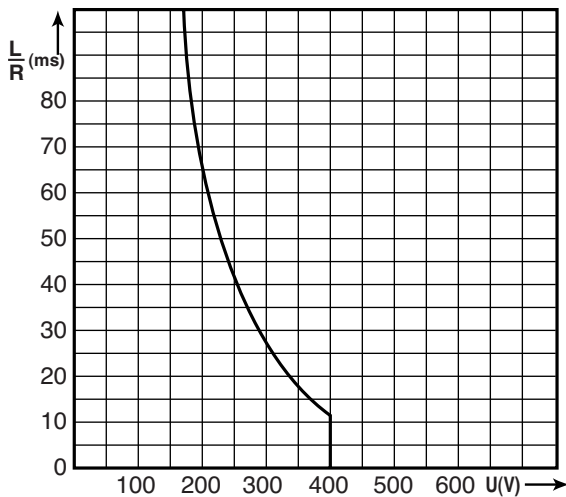

500 V URD $I_N \geq 6A$

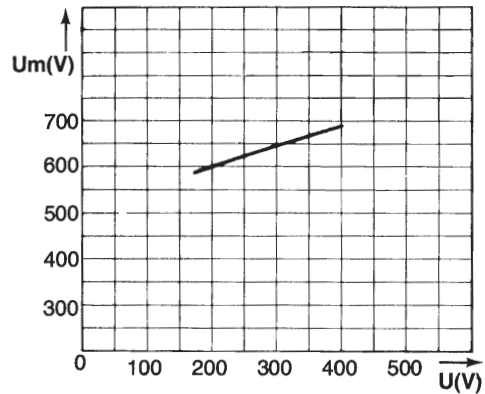

This curve shows the peak value U_m of the arc voltage which appears across the fuse link as a function of the operating voltage U.

Other Protistor® Fuses

Ferrule Fuses

14x51 gRC(URC) - 600 V to 690 VAC



600 - 690 V ~
gRC - URC from 1 to 63 A
Size: 14 x 51

EXTREMELY HIGH BREAKING CAPACITY FUSES: PROTECTION OF SEMICONDUCTORS
COMPLYING WITH IEC STANDARD 60269.1 AND 4

600V - 690 V VOLTAGE RATING (CURRENT RATING 1 TO 50 A)
AS PER IEC 33

gR CLASS (CURRENT RATING 1 TO 50 A) AS PER VDE 636-23

- CLEARING ALL OVERLOADS
- IMPROVED SAFETY AND PROTECTION
- ENABLING SELECTIVE COORDINATION AMONG ALL DISTRIBUTION CIRCUIT FUSES

aR CLASS (CURRENT RATING 63 A) ACCORDING TO VDE 636-23 AND IEC 60269.4

TWO MODELS: WITH OR WITHOUT TRIP-INDICATOR

gRC fuses FROM 8 TO 50 A are 700VAC-DC UL Recognized 

Main Characteristics

Voltage rating U_N U_V	Class	Current rating I_N (A)	Pre-arcing $I^2t @ 1 \text{ ms}$ I^2tp (A ² s)	Total clearing $I^2t @ U_N$ I^2tt (A ² s)	Watts loss		Tested Breaking capacity	Estimated Breaking capacity
					$0.8 I_N$	I_N		
690	gRC	1	0.8/0.31*	3.5/1.4*	0.17	0.35	100k A @ 690 V	300k A @ 690 V
		2	1.5/1*	6.7/4.3*	0.33	0.60		
		4	7.2/6.7*	33/30*	0.77	1.4		
		6	1.4	19	1.3	2.5		
		8	2.4	30	1.5	3.0		
		10	4.3	44	1.75	3.3		
		12	5.4	65	2.25	4.25		
		16	13	110	2.5	4.8		
		20	27	175	2.75	5.25		
		25	53	300	3.0	5.8		
		32	97	550	3.5	7.0		
		40	210	1210	4.5	8.8		
50	390	2250	5.0	10				
600	URC	63	440	2200	8.0	16	100k A @ 600 V	300k A @ 600 V

* I^2t values for fuses without trip-indicator.

Minimum operating voltage for the trip-indicator : 20 V

See Gears and Fuse gears section

Semiconductor (AC) fuses

Other Protistor® Fuses

Ferrule Fuses

14x51 gRC(URC) - 600 V to 690 VAC

14 X 51 Without trip-indicator

Current Rating	Designation	Ref. Number	Catalog Number
1	6.900 Cp gRC 14.51 1	E221080	FR14GC69V1
2	6.900 Cp gRC 14.51 2	H081473	FR14GC69V2
4	6.900 Cp gRC 14.51 4	J081474	FR14GC69V4
6	6.900 Cp gRC 14.51 6	T220909	FR14GC69V6
8	6.900 Cp gRC 14.51 8	S220908	FR14GC69V8
10	6.900 Cp gRC 14.51 10	R220907	FR14GC69V10
12	6.900 Cp gRC 14.51 12	Q220906	FR14GC69V12
16	6.900 Cp gRC 14.51 16	P220905	FR14GC69V16
20	6.900 Cp gRC 14.51 20	E220735	FR14GC69V20
25	6.900 Cp gRC 14.51 25	N220904	FR14GC69V25
32	6.900 Cp gRC 14.51 32	W220819	FR14GC69V32
40	6.900 Cp gRC 14.51 40	M220903	FR14GC69V40
50	6.900 Cp gRC 14.51 50	L220902	FR14GC69V50

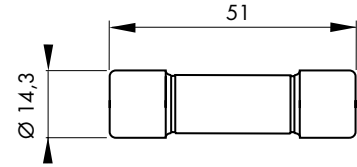

Weight: 18 g
Packaging: 10 pieces

14 X 51 With trip-indicator

1	6.921 Cp gRC 14.51 1	F221081	FR14GC69V1T
2	6.921 Cp gRC 14.51 2	L081476	FR14GC69V2T
4	6.921 Cp gRC 14.51 4	F081517	FR14GC69V4T
6	6.921 Cp gRC 14.51 6	B220939	FR14GC69V6T
8	6.921 Cp gRC 14.51 8	A220938	FR14GC69V8T
10	6.921 Cp gRC 14.51 10	Z220937	FR14GC69V10T
12	6.921 Cp gRC 14.51 12	Y220936	FR14GC69V12T
16	6.921 Cp gRC 14.51 16	X220935	FR14GC69V16T
20	6.921 Cp gRC 14.51 20	W220934	FR14GC69V20T
25	6.921 Cp gRC 14.51 25	V220933	FR14GC69V25T
32	6.921 Cp gRC 14.51 32	V220818	FR14GC69V32T
40	6.921 Cp gRC 14.51 40	M220949	FR14GC69V40T
50	6.921 Cp gRC 14.51 50	N220950	FR14GC69V50T
63	6.21 Cp URC 14.51 63	V220910	FR14UC60V63T

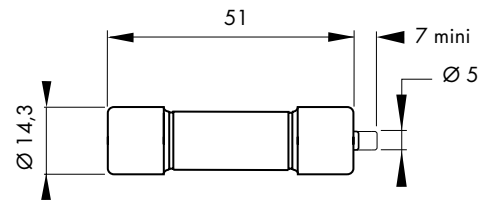

Weight: 18 g
Packaging: 10 pieces



except 1 to 6 and 63A rating

Time vs current characteristics

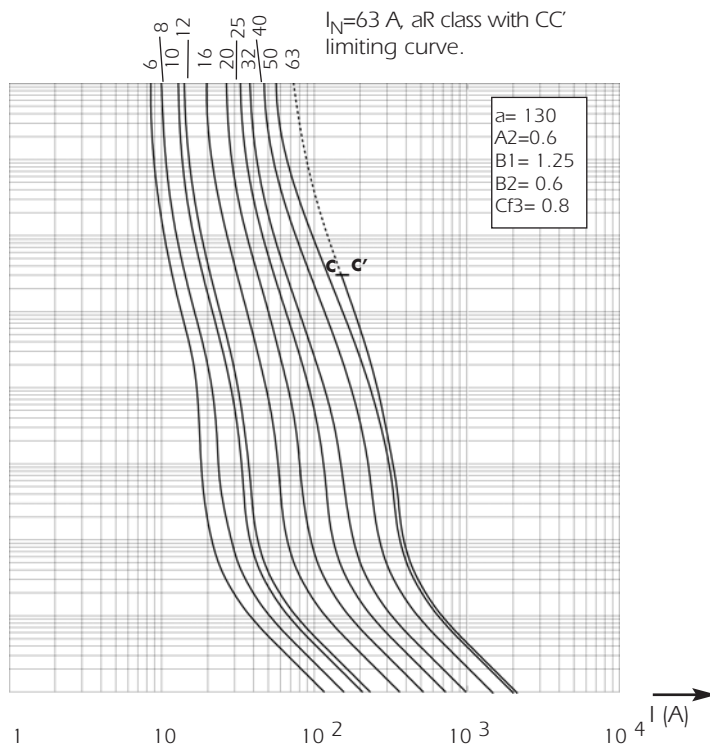
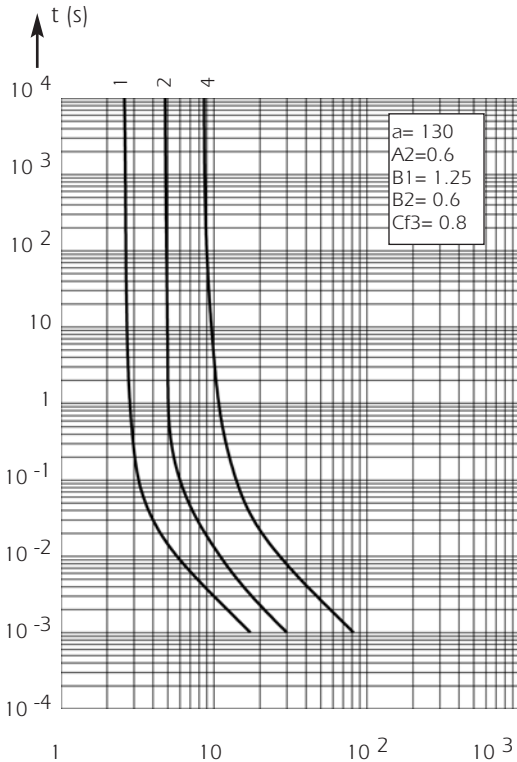

These curves indicate, for each rated current, pre-arcing time vs. R.M.S. pre-arcing current

Tolerance for mean pre-arcing current
± 10% for current rating 1, 2, 4 A
± 8% for current rating 6 to 63 A

Other Protistor® Fuses Ferrule Fuses

14x51 gRC(URC) - 600 V to 690 VAC

Total clearing I²t

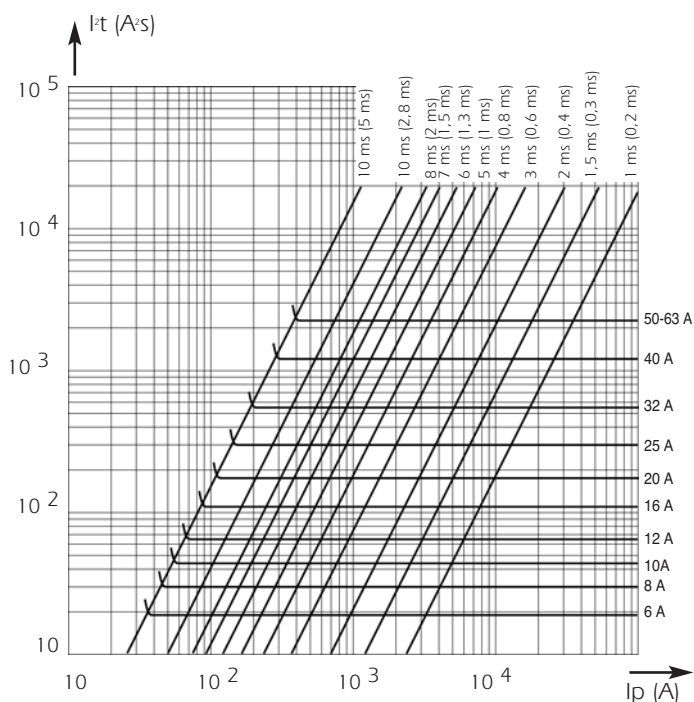

Horizontal curves show maximum values of total clearing I^2t (I^2t_t) for each rated current as a function of prospective current I_p @ 690 V. $\cos \phi = 0.15$ (for 63 A @ 600 V. $\cos \phi = 0.15$). Oblique lines indicate total clearing duration T_t , with associated pre-arcing duration in brackets.

I²t corrective factor

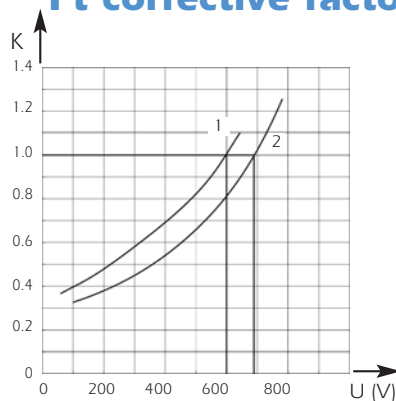

Mean curves showing variation of total clearing time (I^2t_t) and total clearing duration T_t as a function of operating voltage U .
1- 63 A rating - 600 V
2- 1 to 50 A rating - 690 V

Peak arc voltage

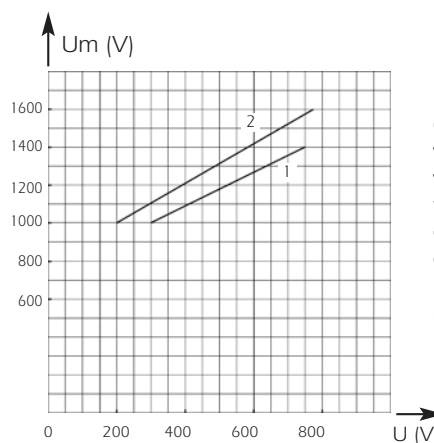

Curves showing peak value U_m of arc voltage which appears across fuse-link as a function of operating voltage U @ $\cos \phi = 0.15$
1-63A rating 600V
2-1 to 50A rating 690V

Current limitation curves

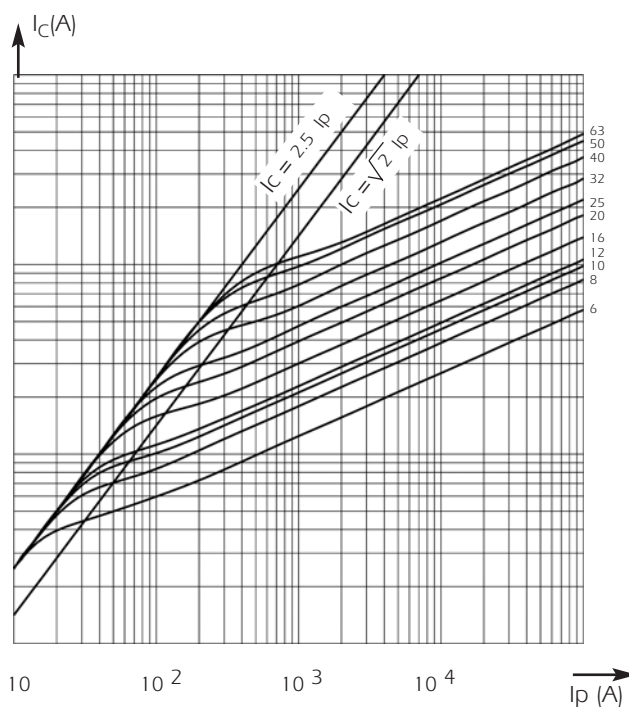
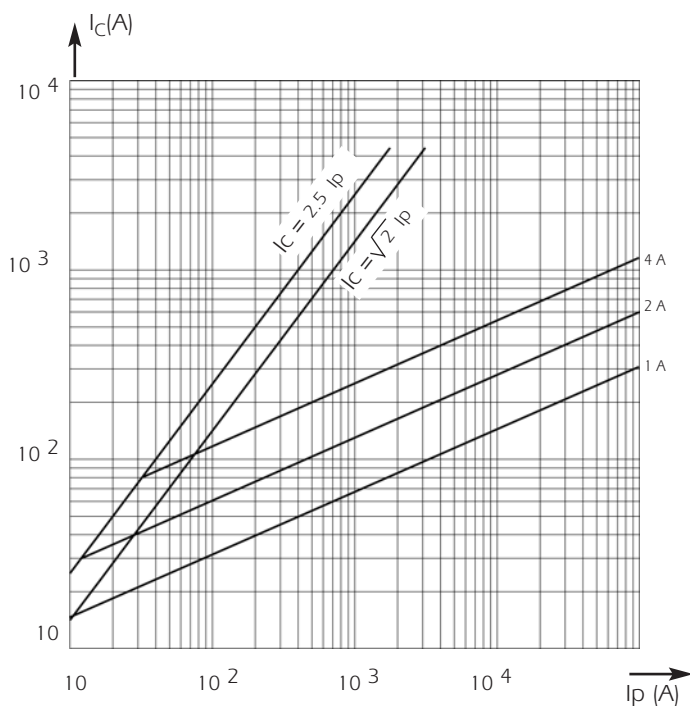

Curves show, for each rating, value of peak let-through current I_C as a function of available fault current I_p .

Semiconductor (AC) fuses

Other Protistor® Fuses

Ferrule Fuses

14x51 gRC(URC) - 600 V to 690 VAC

DC Application data

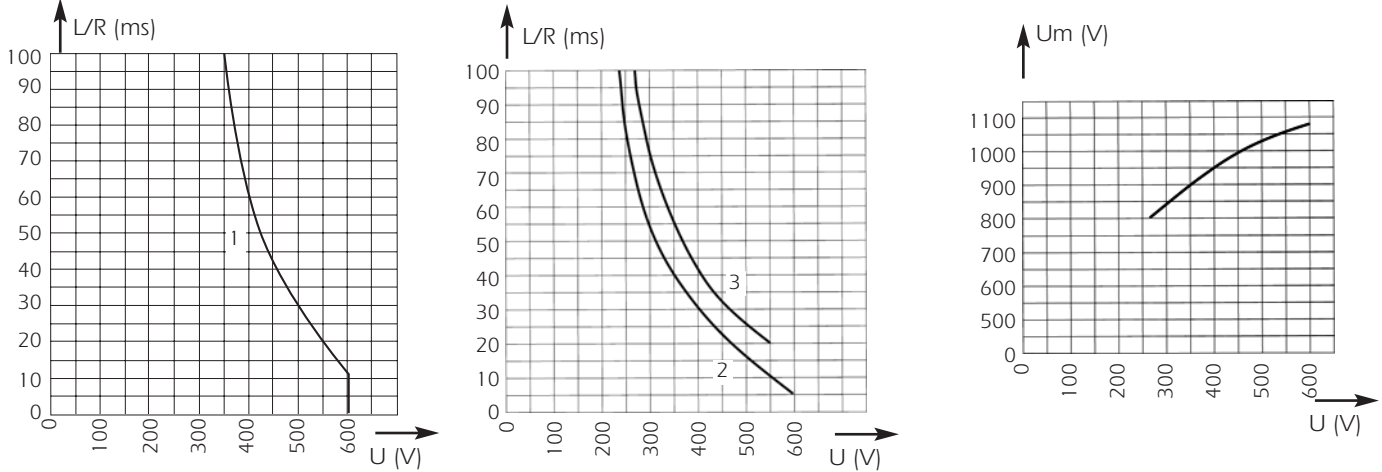

Above, left and center: Curves indicate the permissible value of time constant L/R as a function of DC working voltage:

- 1- For rating 1,2 and 4 A (gRC) $I_p \geq 1,6 I_N$
- 2- $I_p \geq 1,6 I_N$ for gRC only (rating 6 to 50 A)
- 3- $I_p \geq 2,5 I_N$ for gRC and URC (rating 6 to 63 A)

Above, right: Curve indicates peak arc voltage U_m which may appear across fuse terminals at working voltage U .

NEW gR-CLASS

OPTIMAL PROTECTION OF POWER EQUIPMENT

Thanks to recent technological developments, Ferraz Shawmut today markets gR-class PROTISTOR® fuses capable of clearing all types of overloads, from low multiples of current ratings up to very high short-circuit currents. Enhanced performance enables these fuses to provide solutions to many previously unsolved problems in power electronics: protection of cables without the use of additional components, protection of equipment from fire hazards, selective coordination of different fuses within a single power distribution installation...

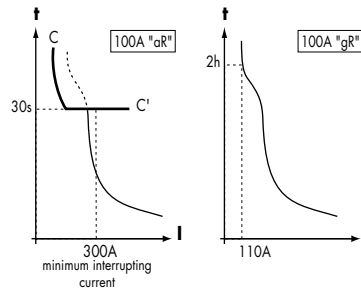

Example:
100A aR vs. 100A gR

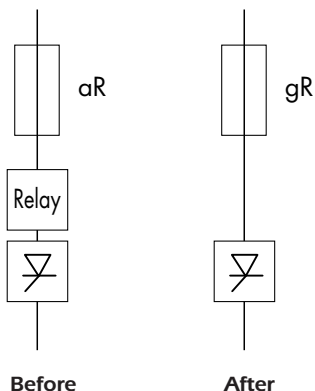

SELECTIVE COORDINATION

gR-class semiconductor fuses can be utilized in association with gI and gG-class low voltage power distribution fuses of the same current rating, installed upstream. In a "selectively coordinated" distribution installation, melting is limited to the fuse associated with the faulted circuit, while upstream fuses remain intact. This prevents unnecessary down-time due to power blackouts in non-faulted branches.

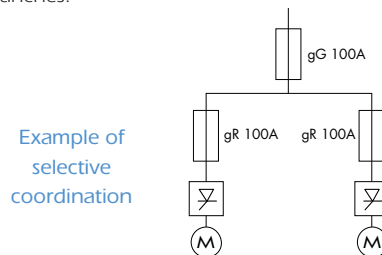

aR-CLASS vs. gR-CLASS

aR-class fuses feature a high minimum interrupting current as compared with their current rating. The primary time-current characteristic of aR-class fuses is the CC' curve, above which another protection device must be associated. The gR-class fuse represents considerably improved performance in semiconductor protection

FERRAZ SHAWMUT EXPERTISE

gR-class fuses should be used in the design of low voltage equipment and in the protection of power electronics equipment. Designers can often substitute a gR-class fuse for an aR-class fuse (10x38, 14x51, 22x58, PSC 000 and 17x49 DIN80 or BS 88-4) but the reverse is not true: an aR fuse can never replace a gR fuse. Start protecting your new equipment with gR-class fuses today. The application of gR class fuses, with current ratings less than 100 Amps, offers enhanced protection, safety and reliability, along with reduced risk of replacement errors and assembly costs.

Other Protistor® Fuses

Ferrule Fuses

22x58 gRC (URD) - 600 V to 690 VAC

EXTREMELY BREAKING CAPACITY RATING FUSES: PROTECTION OF SEMICONDUCTORS

IN COMPLIANCE WITH IEC STANDARD 60269.1 AND 4

600 - 690 V VOLTAGE RATING (CURRENT RATING 12 TO 135 A)
AS PER IEC 33

gR CLASS (CURRENT RATING 12 TO 100 A) ACCORDING TO VDE 636-23

- CLEARING ALL OVERLOADS
- IMPROVED SAFETY AND PROTECTION
- ENABLING SELECTIVE COORDINATION AMONG ALL DISTRIBUTION CIRCUIT FUSES

aR CLASS (CURRENT RATING 125 AND 135 A) AS PER VDE 636-23 AND IEC 60269.4

TWO MODELS COMPLYING WITH NF C 63210 AND 63211
WITH OR WITHOUT TRIP-INDICATOR

gRC FUSES ARE 700VAC-DC UL RECOGNIZED



Main Characteristics

Voltage rating U_N (V)	Class	Current rating I_N (A)	Pre-arcing $I^2t @ 1 \text{ ms}$ I^2_{tp} (A ² s)	Total clearing $I^2t @ U_N$ I^2_{tt} (A ² s)	Watts loss		Tested Breaking capacity	Estimated Breaking capacity
					$0.8 I_N$	I_N		
690	gRC	20	17	125	4.0	6.5	100k A @ 690 V	300k A @ 690 V
		25	39	280	4.5	7.5		
		32	72	490	5.0	9.0		
		40	118	785	5.5	10		
		50	242	1390	7.0	11.5		
		63	430	2460	8.0	13.5		
		80	970	5565	9.0	15.5		
600	URD	125	2900	14000	14	22	100k A @ 600 V	300k A @ 600 V
		135	3360	17700	15	25		

Minimum operating voltage for the trip-indicator: 20 V

See Fuse Blocks and Fuse Holders section

Semiconductor (AC) fuses

Other Protistor® Fuses

Ferrule Fuses

22x58 gRC (URD) - 600 V to 690 VAC

22 X 58 Without trip-indicator

Current rating	Designation	Ref. Number	Catalog Number
12	6,900 CP gRC 22.58 12	F232719	FR22GC69V12
16	6,900 CP gRC 22.58 16	G232720	FR22GC69V16
20	6,900 CP gRC 22.58 20	C220940	FR22GC69V20
25	6,900 CP gRC 22.58 25	B220916	FR22GC69V25
32	6,900 CP gRC 22.58 32	A220915	FR22GC69V32
40	6,900 CP gRC 22.58 40	Z220914	FR22GC69V40
50	6,900 CP gRC 22.58 50	Y220913	FR22GC69V50
63	6,900 CP gRC 22.58 63	X220912	FR22GC69V63
80	6,900 CP gRC 22.58 80	Y220821	FR22GC69V80
100	6,900 CP gRC 22.58 100	W220911	FR22GC69V100

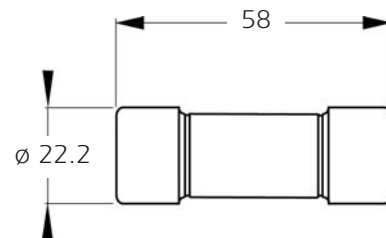

Weight: 57 g
Packaging: 10 pieces

22 X 58 With trip-indicator

20	6,921 CP gRC 22.58 20	D220734	FR22GC69V20T
25	6,921 CP gRC 22.58 25	G220921	FR22GC69V25T
32	6,921 CP gRC 22.58 32	F220920	FR22GC69V32T
40	6,921 CP gRC 22.58 40	E220919	FR22GC69V40T
50	6,921 CP gRC 22.58 50	D220918	FR22GC69V50T
63	6,921 CP gRC 22.58 63	C220733	FR22GC69V63T
80	6,921 CP gRC 22.58 80	X220820	FR22GC69V80T
100	6,921 CP gRC 22.58 100	C220917	FR22GC69V100T
125	621 CP URD 22.58 125	A220708	FR22UD60V125T
135	621 CP URD 22.58 135	B220709	FR22UD60V135T

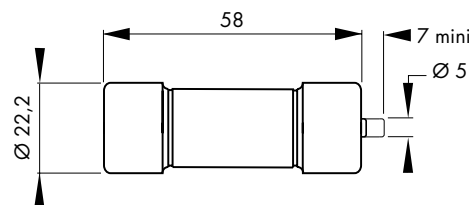

Weight: 57 g
Packaging: 10 pieces



except 125 and 135A rating

Electrical characteristics

Time vs current characteristics

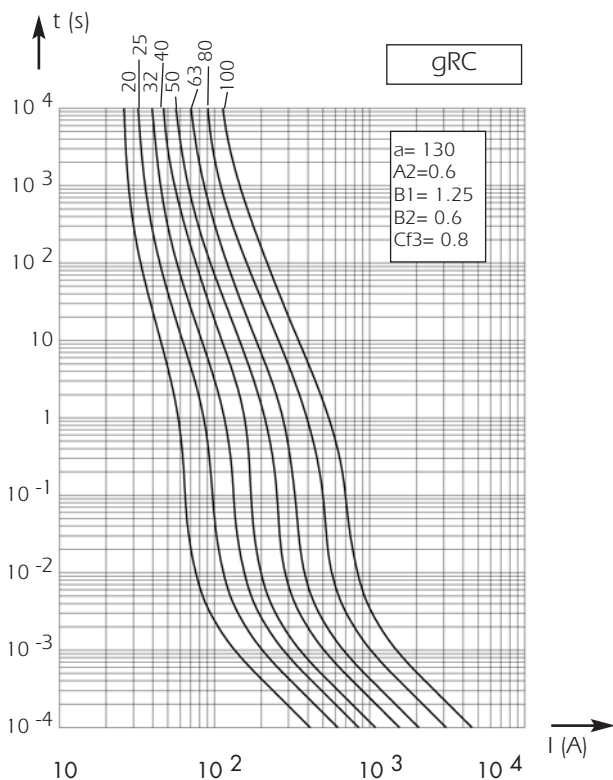

These curves indicate, for each rated current, pre-arcing time vs. R.M.S. pre-arcing current

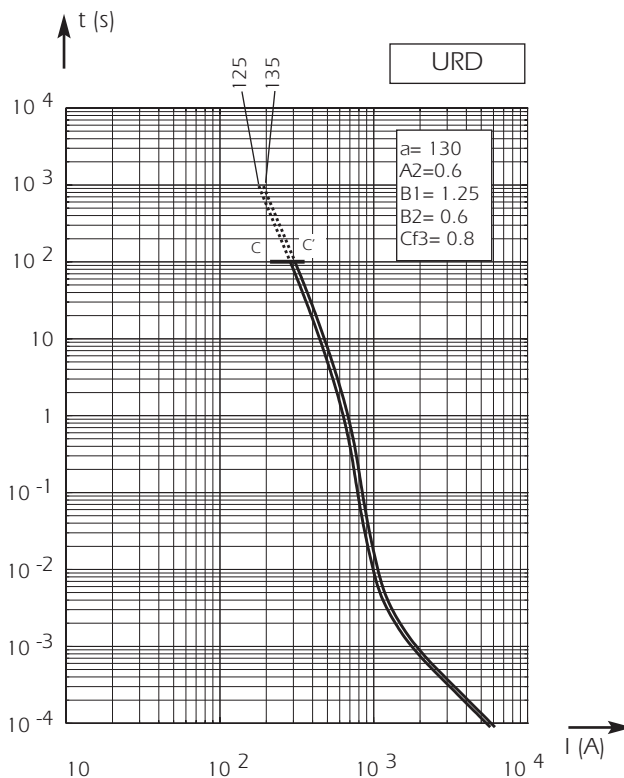

Tolerance for mean pre-arcing current $\pm 9\%$ for all current ratings

Other Protistor® Fuses Ferrule Fuses 22x58 gRC (URD) - 600 V to 690 VAC

Total clearing I²t

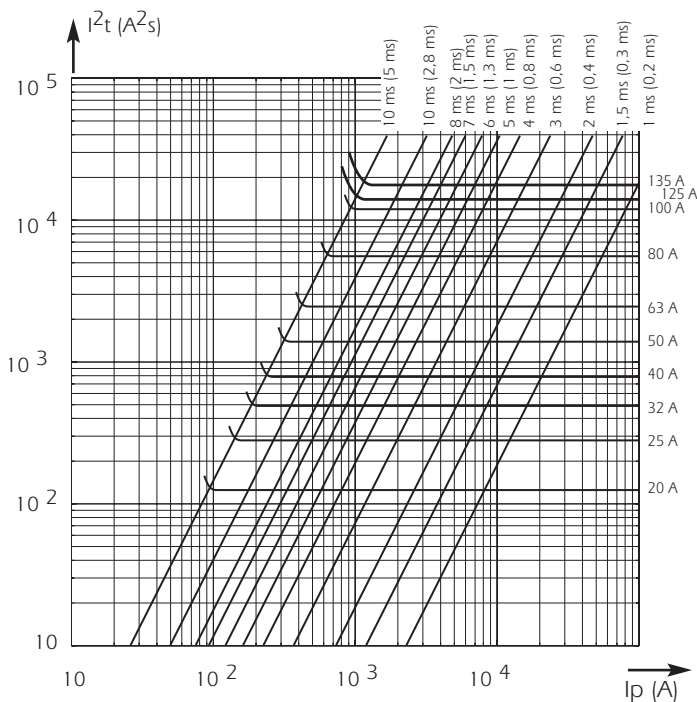

Above: Horizontal curves show, for each rated current, maximum values of total clearing I^2t (I^2t_t) as a function of prospective current I_p @ 690 V. $\cos\phi = 0.15$ (125-135 A @ 600 V. $\cos\phi = 0.15$)
Oblique lines indicate total clearing duration T_t with associated pre-arcing duration in brackets.

I²t corrective factor

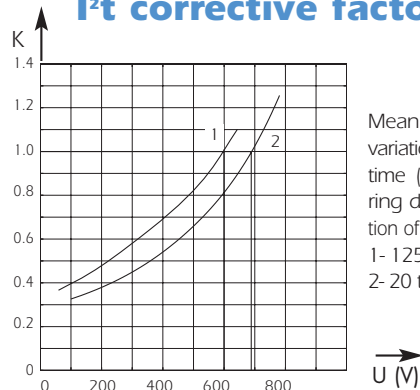

Mean curves showing variation of total clearing time (I^2t_t) and total clearing duration T_t as a function of operating voltage U .
1- 125 and 135 A rating
2- 20 to 100 A rating

Peak arc voltage

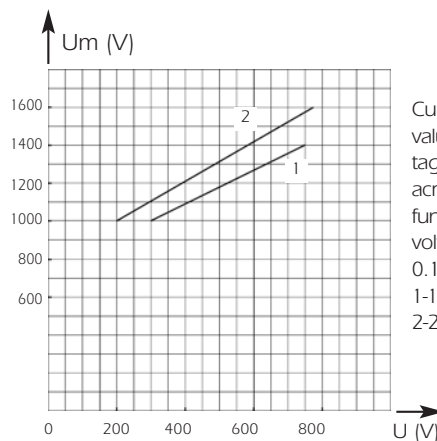

Curve showing peak value U_m of arc voltage which appears across fuse-link as a function of operating voltage U @ $\cos\phi = 0.15$
1-125 and 135A rating
2-20 to 100A rating

Current limitation curves

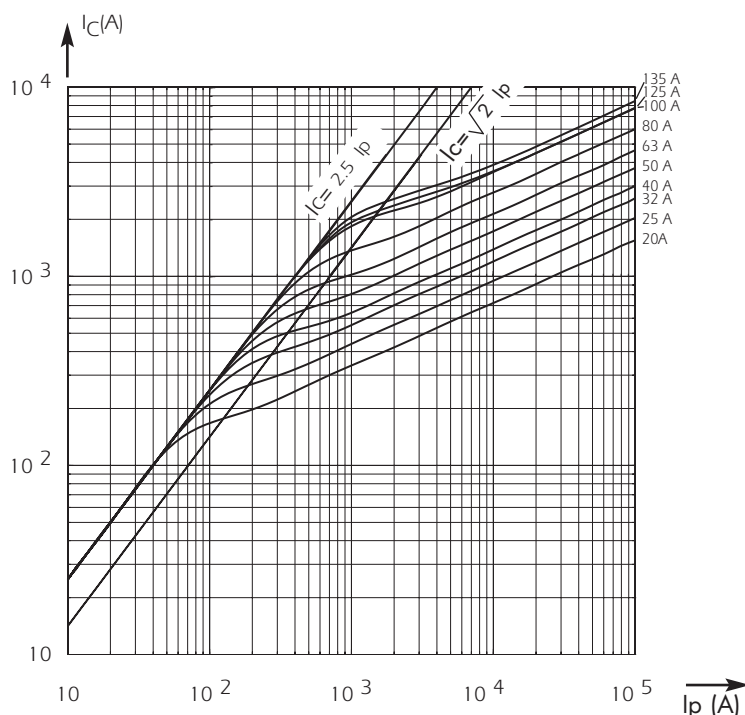

Left: Curves show value of peak let-through current I_C as a function of the available fault current I_p .

Semiconductor (AC) fuses

Other Protistor® Fuses

Ferrule Fuses

22x58 gRC (URD) - 600 V to 690 VAC

DC Application data

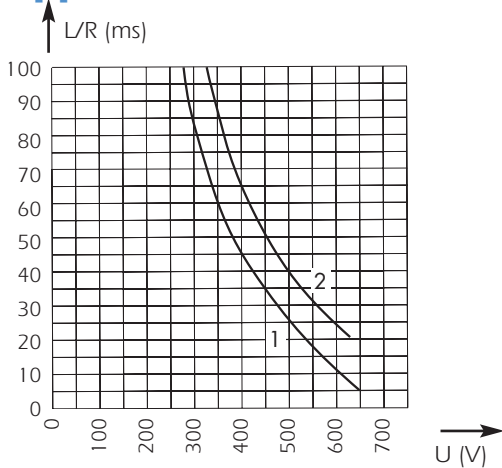

Ces courbes indiquent la constante de temps L/R maximale admissible en fonction de la tension d'utilisation

Courbe 1 : $I_p \geq 1,6 I_n$ pour fusibles gRC uniquement (calibres de 12 à 100 A)

Courbe 2 : $I_p \geq 2,5 I_n$ pour fusibles gRC et URD

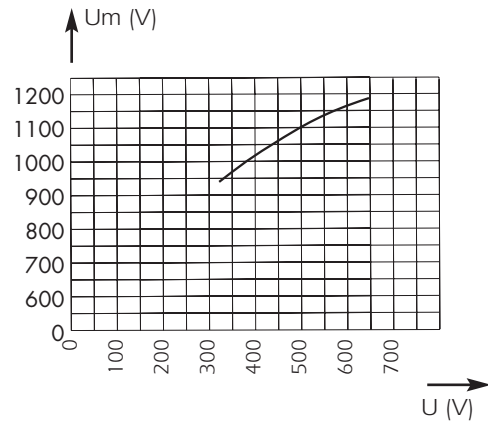

Above: Curve indicates peak arc voltage U_m which may appear across fuse terminals at working voltage U.

NEW gR-CLASS

OPTIMAL PROTECTION OF POWER EQUIPMENT

Thanks to recent technological developments, Ferraz Shawmut today markets gR-class PROTISTOR® fuses capable of clearing all types of overloads, from low multiples of current ratings up to very high short-circuit currents. Enhanced performance enables these fuses to provide solutions to many previously unsolved problems in power electronics: protection of cables without the use of additional components, protection of equipment from fire hazards, selective coordination of different fuses within a single power distribution installation...

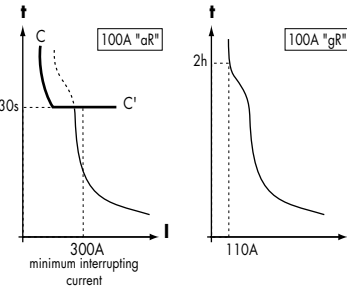

Example:
100A aR vs. 100A gR

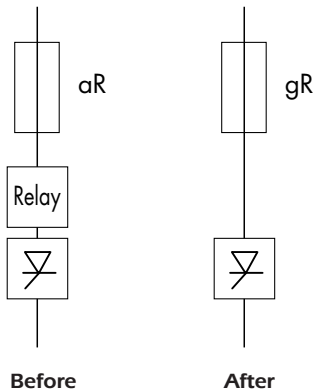

SELECTIVE COORDINATION

gR-class semiconductor fuses can be utilized in association with gI and gG-class low voltage power distribution fuses of the same current rating, installed upstream. In a "selectively coordinated" distribution installation, melting is limited to the fuse associated with the faulted circuit, while upstream fuses remain intact. This prevents unnecessary down-time due to power blackouts in non-faulted branches.

Example of
selective
coordination

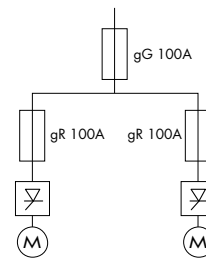

aR-CLASS vs. gR-CLASS

aR-class fuses feature a high minimum interrupting current as compared with their current rating. The primary time-current characteristic of aR-class fuses is the CC' curve, above which another protection device must be associated. The gR-class fuse represents considerably improved performance in semiconductor protection

FERRAZ SHAWMUT EXPERTISE

gR-class fuses should be used in the design of low voltage equipment and in the protection of power electronics equipment. Designers can often substitute a gR-class fuse for an aR-class fuse (10x38, 14x51, 22x58, PSC 000 and 17x49 DIN80 or BS 88-4) but the reverse is not true: an aR fuse can never replace a gR fuse. Start protecting your new equipment with gR-class fuses today. The application of gR class fuses, with current ratings less than 100 Amps, offers enhanced protection, safety and reliability, along with reduced risk of replacement errors and assembly costs.

Other Protistor® Fuses Ferrule Fuses

14x51 & 22x58 URC / URD - 600 to 690 VAC



EXTREMELY BREAKING CAPACITY RATING FUSES:
PROTECTION OF POWER SEMI CONDUCTORS COMPLYING WITH IEC STANDARD 60269.1 AND 4

600 - 690 V AC VOLTAGE RATING

aR-CLASS ACCORDING TO VDE 636-23 AND IEC 60269.4

WITH AND WITHOUT TRIP-INDICATOR FOR SIZES 14 x 51 AND 22 x 58

UL RECOGNIZED (EXCEPT 6 A)*

Main Characteristics

Voltage rating U_N (VAC)	Size	Class	Current rating I_N (A)	Pre-arcing $2t @ 1 \text{ ms}$ I^2t_p (A ² s)	Total clearing $I^2t @$ (A ² s)		Watts loss		Breaking Capacity
					$7 I_N < I_p < 30 I_N$	$I_p \geq 30 I_N$	$0.8 I_N$	I_N	
690 V	14 x 51	URC	6	1.3	17.5* @ 660V		1.1	2	100 kA @ 690 V
			8	2.4	27.5@ 660V		1.6	2.8	
			10	4.3	40@ 660V		2	3.5	
			12	5.4	60@ 660V		2.45	4.4	
			16	13.2	100@ 660V		2.7	4.8	
			20	27	160@ 660V		2.9	5.2	
			25	53	275@ 660V		3.2	5.8	
			32	98	500@ 660V		3.9	7	
			40 (1) 50 (1)	130 280	700@ 660V 1500@ 660V		6 6.3	10.7 11.6	
690 V	14 x 51	URD	40 (2) 50 (2)	130 280	7 IN < I_p < 30 IN		6 6.3	10.7 11.6	100 kA @ 690 V
					$I_p \geq 30 I_N$				
					850@660V 1850@660V	700@660V 1500@660V			
690 V	22 x 58	URD	25	22	125@ 660V		5.2	10	100 kA @ 690 V
			32	49	275@ 660V		5.7	11	
			40	88	480@ 660V		6.8	13	
			50	155	800@ 660V		7.8	14.9	
			63	350	1850@ 660V		8.4	16	
			80	730	3800@ 660V		9.4	17,8	
600 V	22X58	URD	125	2900	14000@600V		14	22	100 kA @ 600 V
			130	3360	17700@600V		15	25	

* Without trip-indicator $I^2t : 15 \text{ A}^2\text{s}$.

(1) No trip-indicator available for this model.

(2) Models available only with trip-indicator.



Other Protistor® Fuses

Ferrule Fuses

14x51 & 22x58 URC / URD - 600 to 690 VAC

All the fuses presented on this page are (except 6 A)* 

14x51 - Without blown fuse indication

Current Rating	Designation	Ref. Number	Catalog Number
6 A	6.900 CP URC 14.51/6*	K081475	FR14UC69V6
8 A	6.900 CP URC 14.51/8	S093902	FR14UC69V8
10 A	6.900 CP URC 14.51/10	T093903	FR14UC69V10
12 A	6.900 CP URC 14.51/12	V093904	FR14UC69V12
16 A	6.900 CP URC 14.51/16	W093905	FR14UC69V16
20 A	6.900 CP URC 14.51/20	X093906	FR14UC69V20
25 A	6.900 CP URC 14.51/25	Y093907	FR14UC69V25
32 A	6.900 CP URC 14.51/32	Z093908	FR14UC69V32
40 A	6.900 CP URC 14.51/40	A093909	FR14UC69V40
50 A	6.900 CP URC 14.51/50	B093910	FR14UC69V50

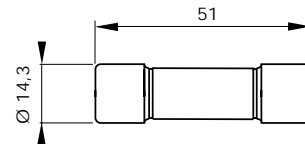

Weight : 18g
Packaging : 10 pieces

14x51 - With trip-indicator

Current Rating	Designation	Ref. Number	Catalog Number
6 A	6.921 CP URC 14.51/6*	G081518	FR14UC69V6T
8 A	6.921 CP URC 14.51/8	C093911	FR14UC69V8T
10 A	6.921 CP URC 14.51/10	D093912	FR14UC69V10T
12 A	6.921 CP URC 14.51/12	E093913	FR14UC69V12T
16 A	6.921 CP URC 14.51/16	F093914	FR14UC69V16T
20 A	6.921 CP URC 14.51/20	G093915	FR14UC69V20T
25 A	6.921 CP URC 14.51/25	H093916	FR14UC69V25T
32 A	6.921 CP URC 14.51/32	J093917	FR14UC69V32T
40 A	6.921 CP URD 14.51/40	T100136	FR14UD69V40T
50 A	6.921 CP URD 14.51/50	V100137	FR14UD69V50T

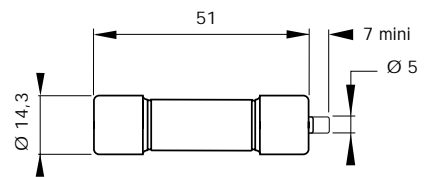

Weight : 18g
Packaging : 10 pieces

22x58 - Without blown fuse indication

Current Rating	Designation	Ref. Number	Catalog Number
25 A	6.900 CP URD 22x58/25	B093956	FR22UD69V25
32 A	6.900 CP URD 22x58/32	Z094828	FR22UD69V32
40 A	6.900 CP URD 22x58/40	S094822	FR22UD69V40
50 A	6.900 CP URD 22x58/50	W094779	FR22UD69V50
63 A	6.900 CP URD 22x58/63	T094823	FR22UD69V63
80 A	6.900 CP URD 22x58/80	A094829	FR22UD69V80
100 A	6.900 CP URD 22x58/100	Y094827	FR22UD69V100

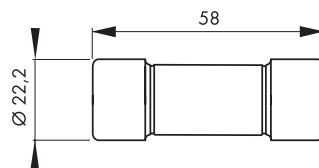

Weight: 57 g
Packaging: 10 pieces

22x58 - With trip-indicator

Current Rating	Designation	Ref. Number	Catalog Number
25 A	6,921 CP URD 22x58/ 25	H093801	FR22UD69V25T
32 A	6,921 CP URD 22x58/ 32	C093957	FR22UD69V32T
40 A	6,921 CP URD 22x58/ 40	J093802	FR22UD69V40T
50 A	6,921 CP URD 22x58/ 50	D093958	FR22UD69V50T
63 A	6,921 CP URD 22x58/ 63	K093803	FR22UD69V63T
80 A	6,921 CP URD 22x58/ 80	E093959	FR22UD69V80T
100 A	6,921 CP URD 22x58/100	F093960	FR22UD69V100T
125 A	621 CP URD 22x58/125	A220708	FR22UD60V125T
135 A	621 CP URD 22x58/135	B220709	FR22UD60V135T

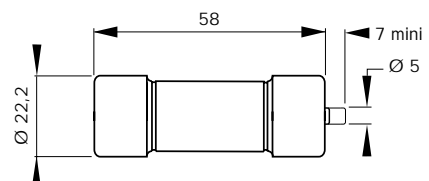

Weight: 57 g
Packaging: 10 pieces

Fuseholder Solution: See Gears and Fuse gears section

Other Protistor® Fuses Ferrule Fuses

14x51 & 22x58 URC / URD - 600 to 690 VAC

Time vs current characteristics

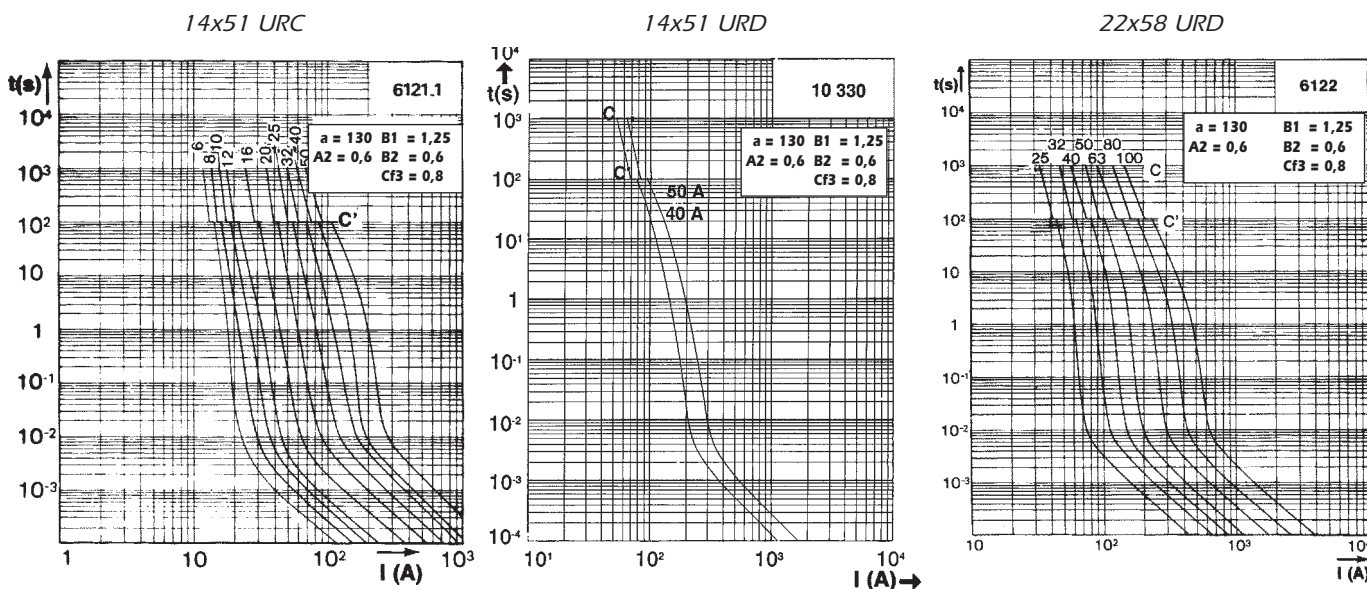

These curves indicate, for each rated current, pre-arcing time vs. R.M.S. pre-arcing current.

Tolerance for mean pre-arcing current $\pm 10\%$

Corrective factor - Peak arc voltage

Corrective factor

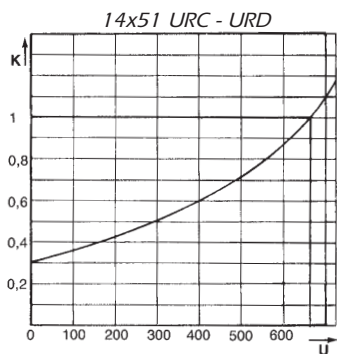

The mean curves show the variation of the total clearing Pt_t and the total clearing duration t_t as a function of operating voltage U .

Peak arc voltage

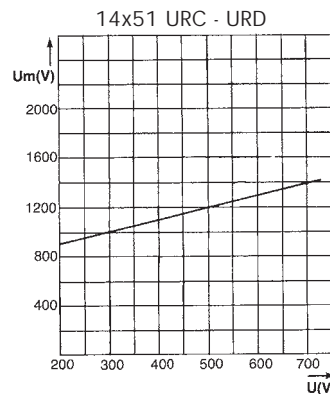

This curve shows the peak value U_m of the arc voltage which appears across the fuse-link as a function of the operating voltage $U @ \cos j = 0.15$.

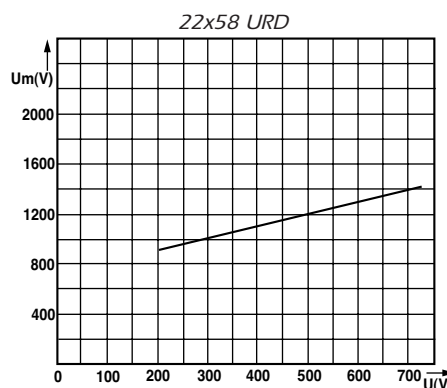
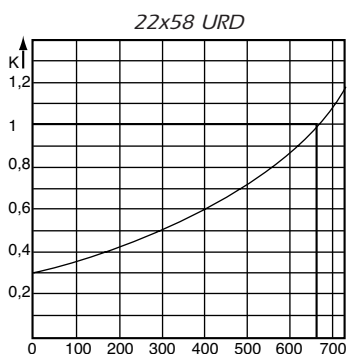



Other Protistor® Fuses

Ferrule Fuses

14x51 & 22x58 URC / URD - 600 to 690 VAC

DC Application data

14x51 URC - URD

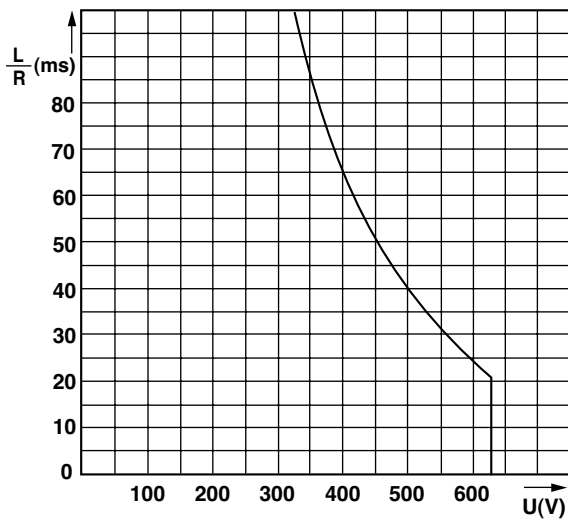

14x51 URC - URD

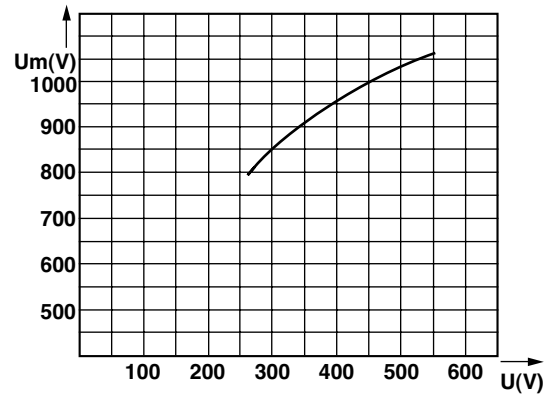

Minimum breaking current: see time-current characteristics

22x58 URD

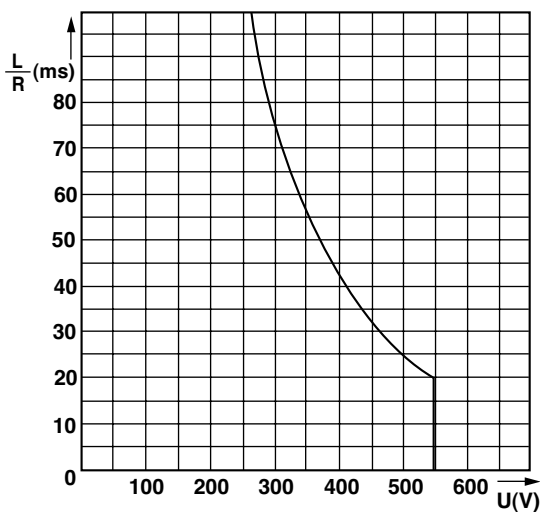

22x58 URD

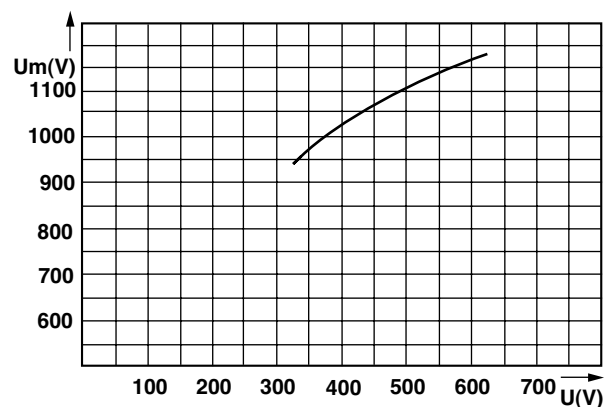

This curve indicates the permissible value of time constant L/r as a function of DC working voltage

This curve shows the peak value U_m of the arc voltage which appears across the fuse-link as a function of the operating voltage U .

Other Protistor® Fuses Ferrule Fuses

14x51 URGB & 22x58 URGA - 600 V to 690 VAC



EXTREMELY HIGH BREAKING CAPACITY FUSES:
PROTECTION OF POWER SEMICONDUCTORS AS PER
IEC STANDARD 60269.1 AND 4

600 V - 690 V AC VOLTAGE RATING

aR CLASS AS PER VDE 636-23 AND IEC 60269.4

WITH AND WITHOUT TRIP-INDICATOR
FOR SIZES 14 x 51 AND 22 x 58

Main Characteristics

Voltage rating U_N (VAC)	Size	Class	Current rating I_N (A)	Pre-arcing $I^2t @ 1 ms$ I^2tp (A ² s)	Total clearing $I^2t @ A^2s$		Watts loss		Tested Breaking capacity
					660 V		0,8 I_N	I_N	
					$I_p \leq 30 I_N$	$I_p > 30 I_N$			
690 V	14 x 51	URGB	8	3.3	20	17	1.45	2.7	200 kA @ 690 V
			10	6.0	37	30	1.85	3.4	
			12	9.3	75	60	2.5	4.6	
			16	15.6	95	75	3.4	6.2	
			20	30.0	175	145	4	7.4	
			25	53.5	300	250	4.7	8.6	
			32	100	550	460	5.7	10.6	
			40	214	1150	940	6.2	11.5	
	50	480	2550	2070	7	13			
	22 x 58	URGA	25	45	210		4.7	8.5	
			32	84	400		5.7	10.3	
			40	150	700		7.1	12.8	
			50	270	1270		8.7	15.7	
			63	595	2770		9.8	17.7	
80			1165	5500		12	21.7		
600* - 690 V	22 x 58	URGA	100*	2150	9000*		14.2	25.6	200 kA @600 V

*Operating voltage limited to 600 V for the model with blown fuse trip-indicator / Total clearing $I^2t @ 600 V = 9000 A^2s$
Minimum operating voltage for built-in trip-indicator: 20 V



Other Protistor® Fuses

Ferrule Fuses

14x51 URGB & 22x58 URGA - 600 V to 690 VAC

References

14x51 - Without blown fuse trip-indicator

Current Rating	Designation	Ref. Number	Catalog Number
8 A	6.900 CP URGB 14.51/8	T078033	FR14UB69V8
10 A	6.900 CP URGB 14.51/10	V078034	FR14UB69V10
12 A	6.900 CP URGB 14.51/12	W078035	FR14UB69V12
16 A	6.900 CP URGB 14.51/16	X078036	FR14UB69V16
20 A	6.900 CP URGB 14.51/20	Y078037	FR14UB69V20
25 A	6.900 CP URGB 14.51/25	Z078038	FR14UB69V25
32 A	6.900 CP URGB 14.51/32	A078039	FR14UB69V32
40 A	6.900 CP URGB 14.51/40	B078040	FR14UB69V40
50 A	6.900 CP URGB 14.51/50	C078041	FR14UB69V50

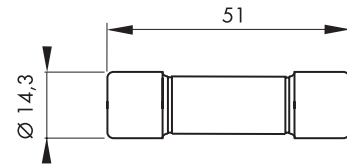

Weight: 18 g
Packaging: 10 pieces

14x51 - With trip-indicator

Current Rating	Designation	Ref. Number	Catalog Number
8 A	6.921 CP URGB 14.51/8	D078042	FR14UB69V8T
10 A	6.921 CP URGB 14.51/10	E078043	FR14UB69V10T
12 A	6.921 CP URGB 14.51/12	F078044	FR14UB69V12T
16 A	6.921 CP URGB 14.51/16	G078045	FR14UB69V16T
20 A	6.921 CP URGB 14.51/20	H078046	FR14UB69V20T
25 A	6.921 CP URGB 14.51/25	J078047	FR14UB69V25T
32 A	6.921 CP URGB 14.51/32	K078048	FR14UB69V32T
40 A	6.921 CP URGB 14.51/40	L078049	FR14UB69V40T
50 A	6.921 CP URGB 14.51/50	M078050	FR14UB69V50T

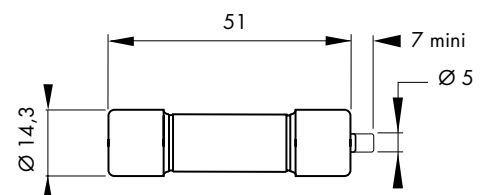

Weight: 18 g
Packaging: 10 pieces

22x58 - Without blown fuse trip-indicator

Current Rating	Designation	Ref. Number	Catalog Number
25 A	6.900 CP URGA 22.58/25	C095245	FR22UA69V25
32 A	6.900 CP URGA 22.58/32	D095246	FR22UA69V32
40 A	6.900 CP URGA 22.58/40	E095247	FR22UA69V40
50 A	6.900 CP URGA 22.58/50	F095248	FR22UA69V50
63 A	6.900 CP URGA 22.58/63	G095249	FR22UA69V63
80 A	6.900 CP URGA 22.58/80	H095250	FR22UA69V80
100 A	6.900 CP URGA 22.58/100	N078051	FR22UA69V100

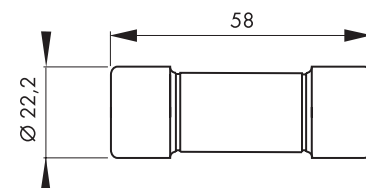

Weight: 57 g
Packaging: 10 pieces

22x58 - With trip-indicator

Current Rating	Designation	Ref. Number	Catalog Number
25 A	6.921 CP URGA 22.58/25	T095260	FR22UA69V25T
32 A	6.921 CP URGA 22.58/32	V095261	FR22UA69V32T
40 A	6.921 CP URGA 22.58/40	W095262	FR22UA69V40T
50 A	6.921 CP URGA 22.58/50	X095263	FR22UA69V50T
63 A	6.921 CP URGA 22.58/63	Y095264	FR22UA69V63T
80 A	6.921 CP URGA 22.58/80	Z095265	FR22UA69V80T
100 A	6.21 CP URGA 22.58/100	N098222	FR22UA60V100T

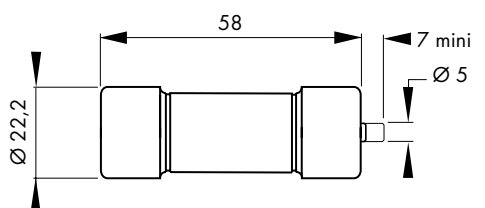

Weight: 57 g
Packaging: 10 pieces

See Gears and Fuse gears section

Other Protistor® Fuses Ferrule Fuses

14x51 URGB & 22x58 URGA - 600 V to 690 VAC

Electrical Characteristics

Time vs current characteristics

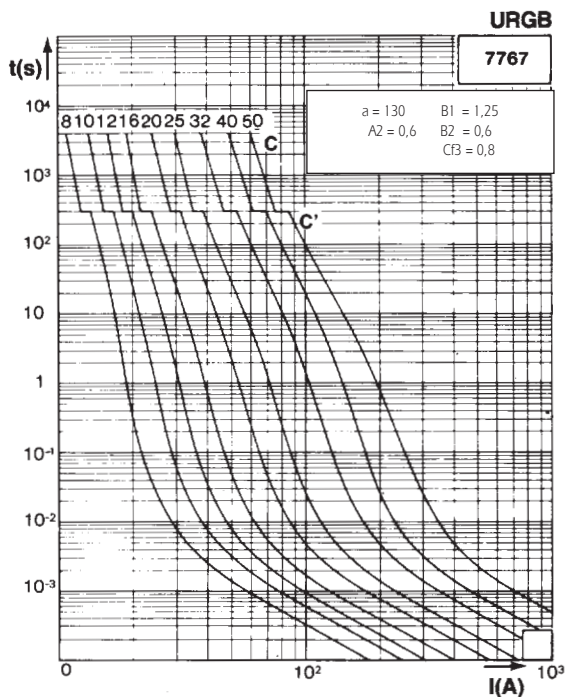

TOLERANCE OF MEAN PRE-ARCING CURRENT $\pm 10\%$

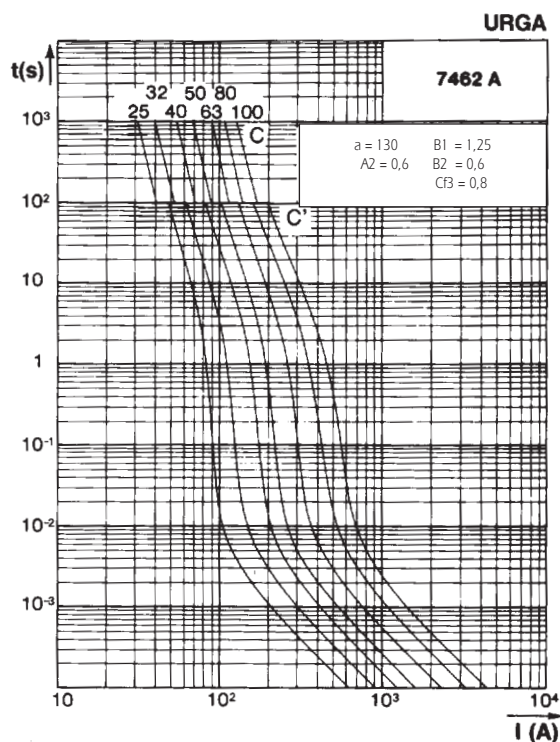

TOLERANCE FOR MEAN PRE-ARCING CURRENT $\pm 8\%$.

These curves indicate, for each rated current, pre-arcing time vs. R.M.S. pre-arcing current.



Other Protistor® Fuses

Ferrule Fuses

14x51 URGB & 22x58 URGA - 600 V to 690 VAC

Corrective factor - Peak arc voltage

Corrective factor

Peak arc voltage

URGB

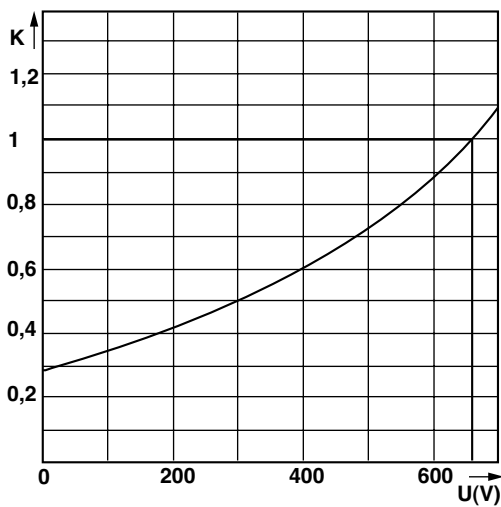

URGB

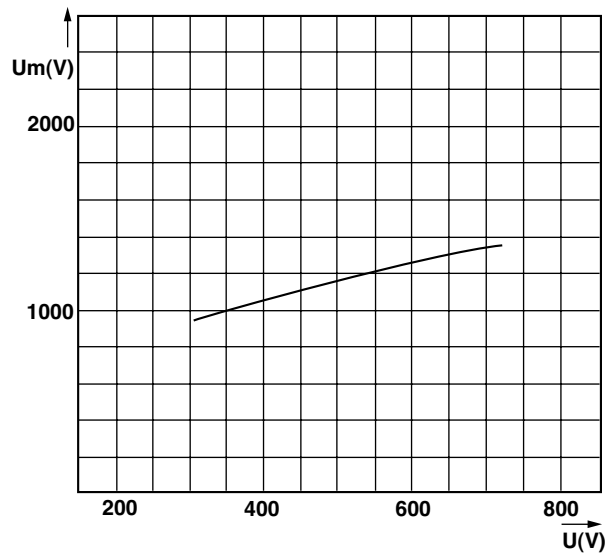

URGA

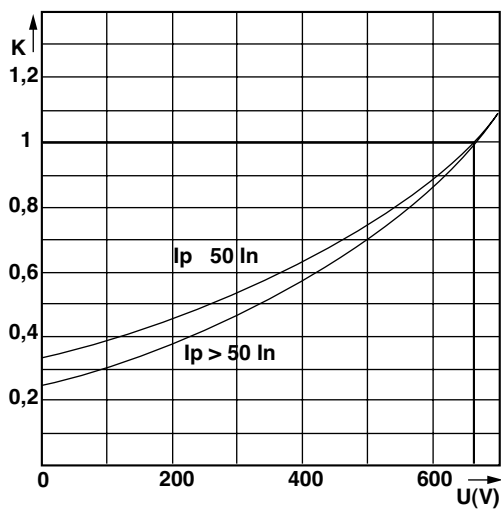

URGA

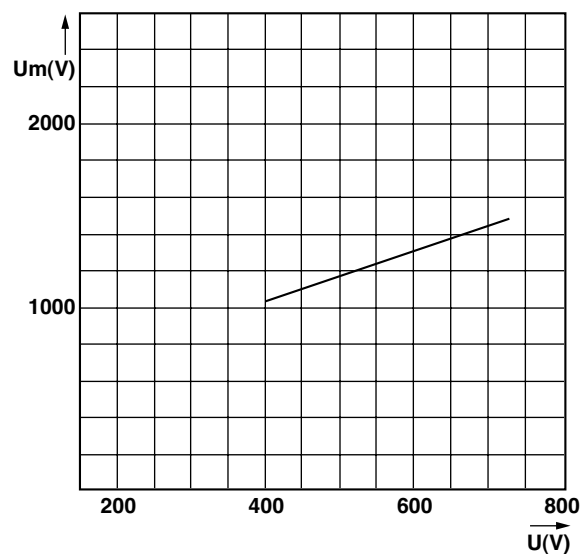

These mean curves show the variation of the total clearing time (I^2t_t) and the total clearing duration t_t as a function of operating voltage U .

This curve shows the peak value U_m of the arc voltage which appears across the fuse link as a function of operating voltage U @ $\cos \varphi = 0.15$.