

“PHOENIX” FIRE RATED STAINLESS STEEL CABLE CLAMPS

Applications:

- Support fire-rated cables in event of a fire.

Features:

- Successfully tested for fire resistance in accordance with BS8491:2008 and BS 5839-1:2002, Section 26.2d.
- Successfully tested to 60kA peak @ 0.1 sec to IEC 61914:2009.
- Manufactured from 316L marine grade stainless steel.
- Supplied in pairs.

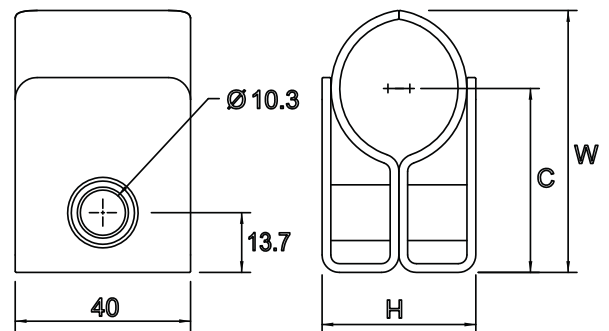

SELECTION TABLE

Part No.	Single Cable Range		Dimensions				Approx. weight g
	Min O/D mm	Max O/D mm	H		W mm	C mm	
EP1FP-10SS	10	13	18.1	21.1	40.3	32	91
EP1FP-11SS	13	16	21.1	24.1	43.8	34	106
EP1FP-12SS	16	19	24.1	27.1	46.9	35.5	114
EP1FP-13SS	19	23	27.1	31.1	50.8	37.5	126
EP1FP-14SS	23	27	31.1	35.1	55.3	40	140
EP1FP-15SS	27	32	35.1	40.1	59.8	42	155
EP1FP-16SS	32	38	40.1	46.1	65.7	45	176
EP1FP-17SS	38	46	46.1	54.1	73.6	49	202
EP1FP-18SS	46	51	54.1	59.1	79.4	52	225
EP1FP-19SS	51	57	59.1	64.1	85.3	55	245
EP1FP-20SS	57	65	65.1	73.1	93.2	59	265



Circuit integrity test